

FEATURES

- ❑ 20 ns Multiply-Accumulate Time
- ❑ Replaces Fairchild TMC2210, Cypress CY7C510, IDT 7210L, and AMD Am29510
- ❑ Two's Complement or Unsigned Operands
- ❑ Accumulator Performs Preload, Accumulate, and Subtract
- ❑ Three-State Outputs
- ❑ 68-pin PLCC, J-Lead

DESCRIPTION

The **LMA1010** and **LMA2010** are high-speed, low power 16-bit multiplier-accumulators. The **LMA1010** and **LMA2010** are functionally identical; they differ only in packaging. Full military ambient temperature range operation is achieved with advanced CMOS technology.

The **LMA1010** and **LMA2010** produce the 32-bit product of two 16-bit numbers. The results of a series of multiplications may be accumulated to form the sum of products. Accumulation is performed to 35-bit precision with the multiplier product sign extended as appropriate.

Data present at the A and B input registers is latched on the rising edges of **CLKA** and **CLKB** respectively.

RND, **TC**, **ACC**, and **SUB** controls are latched on the rising edge of the logical OR of **CLKA** and **CLKB**. **TC** specifies the input as two's complement (**TC HIGH**) or unsigned magnitude (**TC LOW**). **RND**, when **HIGH**, adds '1' to the most significant bit position of the least significant half of the product. Subsequent truncation of the 16 least significant bits produces a result correctly rounded to 16-bit precision.

ACC and **SUB** control accumulator operation. **ACC HIGH** results in addition of the multiplier product and the accumulator contents, with the result stored in the accumulator register on the rising edge of **CLKR**. **ACC** and **SUB HIGH** results in subtraction of the accumulator contents from the multiplier product, with the result stored in the accumulator register. With **ACC LOW** and **SUB LOW**, no accumulation occurs and the next product is loaded directly into the accumulator register. **ACC LOW** and **SUB HIGH** is undefined.

The **LMA1010/2010** output register (accumulator register) is divided into three independently controlled sections. The least significant result (**LSR**) and most significant result (**MSR**) registers are 16 bits in length. The extended result register (**XTR**) is 3 bits long. The output signals **R15-0** and input signals **B15-0** share the same bidirectional pins.

Each output register has an independent output enable control. In addition to providing three-state control of the output buffers, when **OEX**, **OEM**, or **OEL** are **HIGH** and **PREL** is **HIGH**, data can be preloaded via the bidirectional output pins into the respective output registers. Data present on the output pins is latched on the rising edge of **CLKR**. The interrelation of **PREL** and the enable controls is summarized in Table 1.

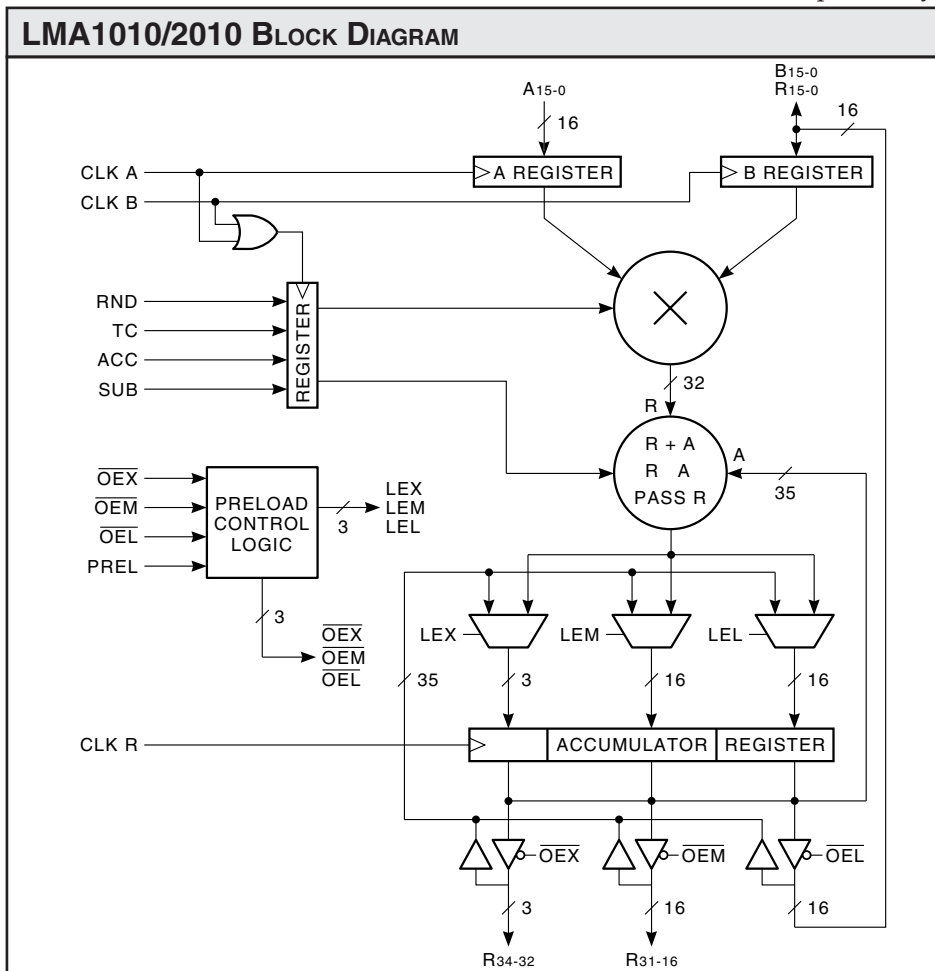

16 x 16-bit Multiplier-Accumulator

TABLE 1. PRELOAD TRUTH TABLE

PREL	OEX	OEM	OEL	XTR	MSR	LSR
L	L	L	L	OUT	OUT	OUT
L	L	L	H	OUT	OUT	Z
L	L	H	L	OUT	Z	OUT
L	L	H	H	OUT	Z	Z
L	H	L	L	Z	OUT	OUT
L	H	L	H	Z	OUT	Z
L	H	H	L	Z	Z	OUT
L	H	H	H	Z	Z	Z
H	L	L	L	Z	Z	Z
H	L	L	H	Z	Z	PREL
H	L	H	L	Z	PREL	Z
H	L	H	H	Z	PREL	PREL
H	H	L	L	PREL	Z	Z
H	H	L	H	PREL	Z	PREL
H	H	H	L	PREL	PREL	Z
H	H	H	H	PREL	PREL	PREL

PREL = Preload data to appropriate register
 OUT = Register available on output pins
 Z = High impedance state

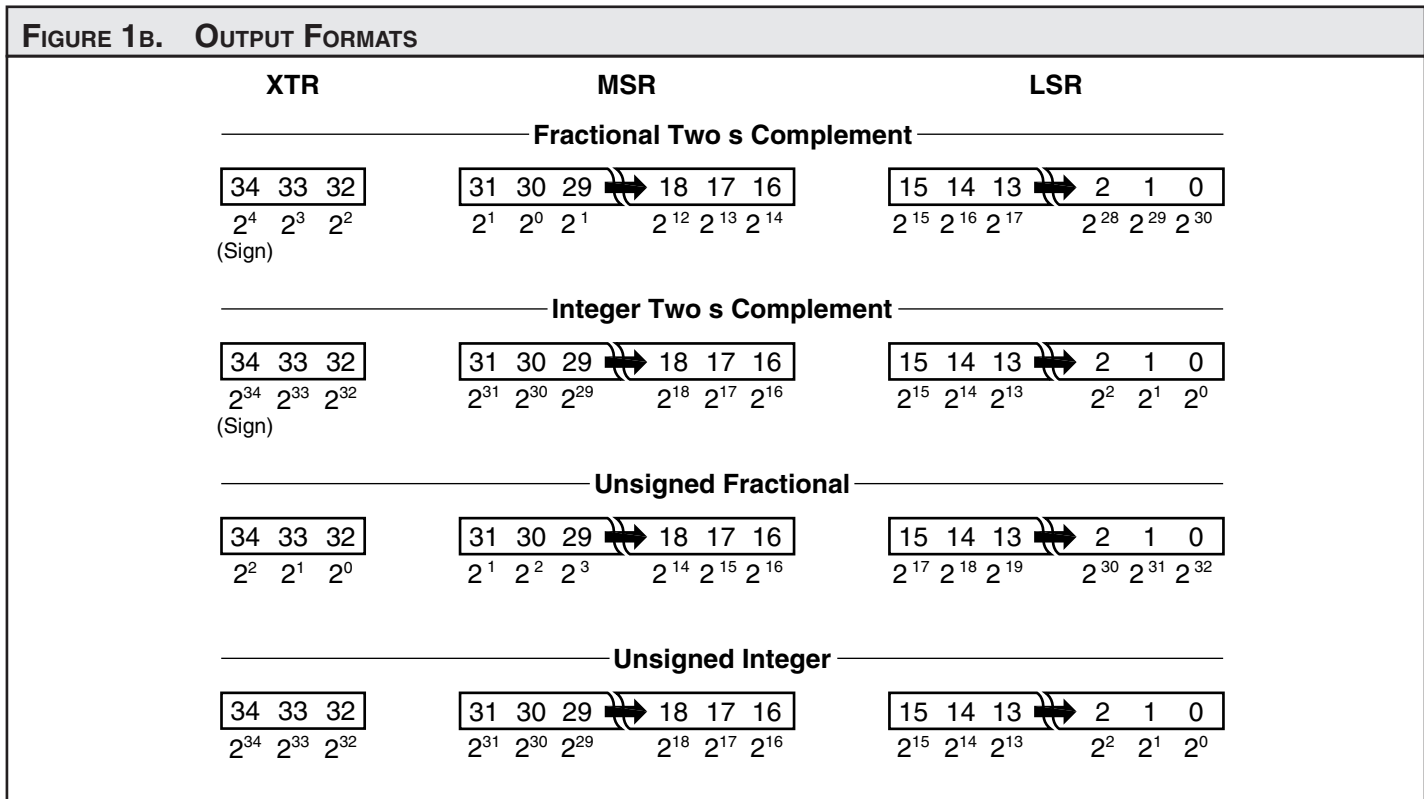
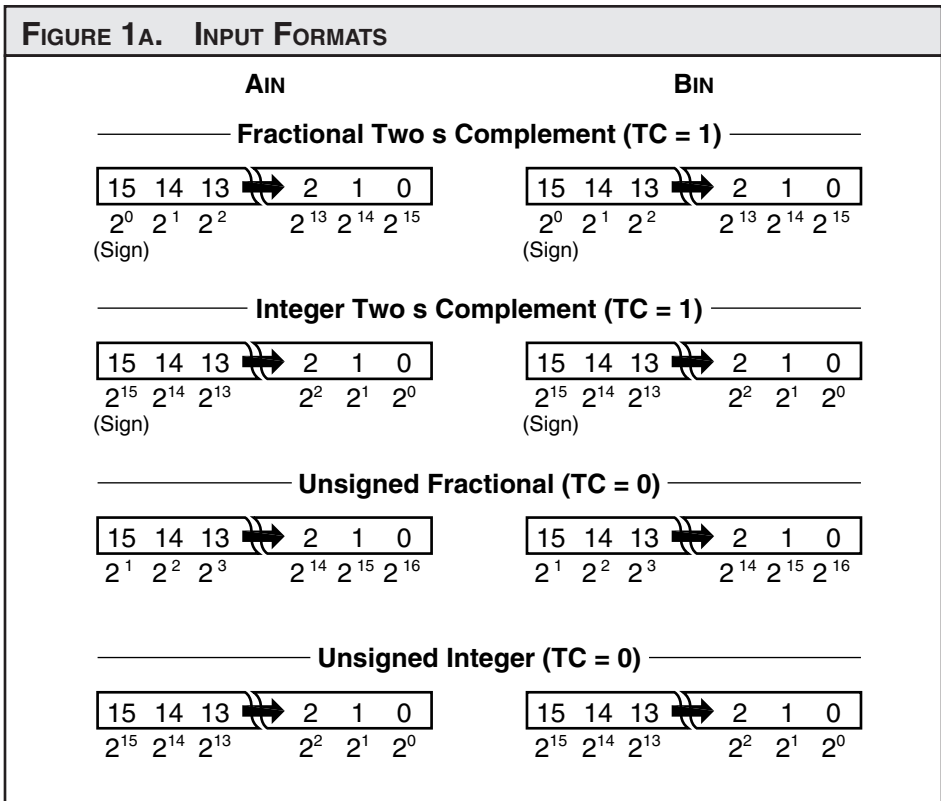

MAXIMUM RATINGS <i>Above which useful life may be impaired (Notes 1, 2, 3, 8)</i>	
Storage temperature	-65°C to +150°C
Operating ambient temperature	-55°C to +125°C
V _{CC} supply voltage with respect to ground	-0.5V to +7.0V
Input signal with respect to ground	-3.0V to +7.0 V
Signal applied to high impedance output	-3.0V to +7.0 V
Output current into low outputs	25 mA
Latchup current	> 400 mA

OPERATING CONDITIONS <i>To meet specified electrical and switching characteristics</i>		
Mode	Temperature Range (Ambient)	Supply Voltage
Active Operation, Commercial	0°C to +70°C	4.75V ≤ V _{CC} ≤ 5.25V
Active Operation, Industrial	-40°C to +85°C	4.75V ≤ V _{CC} ≤ 5.25V
Active Operation, Military	-55°C to +125°C	4.50V ≤ V _{CC} ≤ 5.50V

ELECTRICAL CHARACTERISTICS <i>Over Operating Conditions (Note 4)</i>						
Symbol	Parameter	Test Condition	Min	Typ	Max	Unit
V _{OH}	Output High Voltage	V _{CC} = Min., I _{OH} = -2.0 mA	2.4			V
V _{OL}	Output Low Voltage	V _{CC} = Min., I _{OL} = 8.0 mA			0.5	V
V _{IH}	Input High Voltage		2.0		V _{CC}	V
V _{IL}	Input Low Voltage	(Note 3)	0.0		0.8	V
I _{Ix}	Input Current	Ground ≤ V _{IN} ≤ V _{CC} (Note 12)			±20	μA
I _{OZ}	Output Leakage Current	Ground ≤ V _{OUT} ≤ V _{CC} (Note 12)			±20	μA
I _{CC1}	V _{CC} Current, Dynamic	(Notes 5, 6)		12	25	mA
I _{CC2}	V _{CC} Current, Quiescent	(Note 7)			1.0	mA

16 x 16-bit Multiplier-Accumulator

SWITCHING CHARACTERISTICS

COMMERCIAL AND INDUSTRIAL OPERATING RANGE (0°C to +70°C) or (-40°C to +85°C) Notes 9, 10 (ns)															
Symbol		Parameter		LMA1010/2010-											
				65*		55*		45*		35*		25		20*	
				Min	Max	Min	Max	Min	Max	Min	Max	Min	Max	Min	Max
t _{MC}	Clocked Multiply Time		65		55		45		35		25		20		
t _{PW}	Clock Pulse Width	15		15		15		10		10		9			
t _S	Input Register Setup Time	15		15		12		12		12		10			
t _H	Input Register Hold Time	2		2		2		2		2		2			
t _{SP}	Preload Setup Time	15		15		12		12		12		10			
t _{HP}	Preload Hold Time	2		2		2		2		2		2			
t _D	Output Delay		30		25		25		25		20		18		
t _{ENA}	Three-State Output Enable Delay (Note 11)		30		30		25		25		20		18		
t _{DIS}	Three-State Output Disable Delay (Note 11)		30		25		25		25		20		18		

MILITARY OPERATING RANGE (-55°C to +125°C) Notes 9, 10 (ns)															
Symbol		Parameter		LMA1010/2010-											
				75*		65*		55*		40*		30*		25*	
				Min	Max	Min	Max	Min	Max	Min	Max	Min	Max	Min	Max
t _{MC}	Clocked Multiply Time		75		65		55		40		30		25		
t _{PW}	Clock Pulse Width	20		15		15		15		10		10			
t _S	Input Register Setup Time	20		15		15		15		12		12			
t _H	Input Register Hold Time	2		2		2		2		2		2			
t _{SP}	Preload Setup Time	20		15		15		15		12		12			
t _{HP}	Preload Hold Time	2		2		2		2		2		2			
t _D	Output Delay		35		30		30		25		20		20		
t _{ENA}	Three-State Output Enable Delay (Note 11)		35		30		30		25		20		20		
t _{DIS}	Three-State Output Disable Delay (Note 11)		35		25		25		25		20		20		

SWITCHING WAVEFORMS

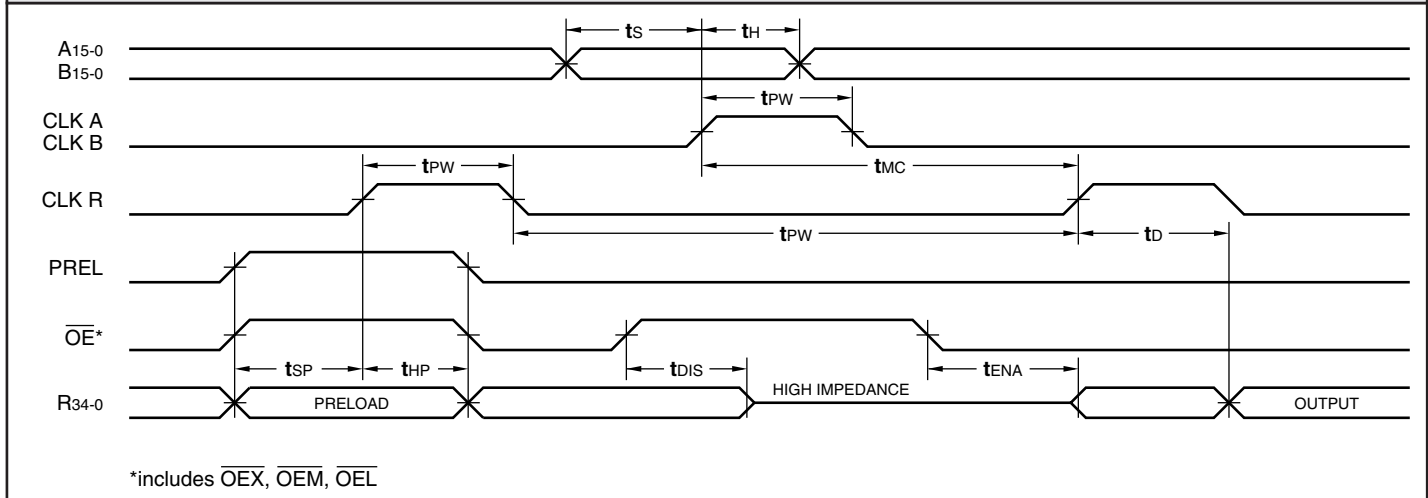

***DISCONTINUED SPEED GRADE**

NOTES

1. Maximum Ratings indicate stress specifications only. Functional operation of these products at values beyond those indicated in the Operating Conditions table is not implied. Exposure to maximum rating conditions for extended periods may affect reliability.

2. The products described by this specification include internal circuitry designed to protect the chip from damaging substrate injection currents and accumulations of static charge. Nevertheless, conventional precautions should be observed during storage, handling, and use of these circuits in order to avoid exposure to excessive electrical stress values.

3. This device provides hard clamping of transient undershoot and overshoot. Input levels below ground or above VCC will be clamped beginning at -0.6 V and VCC + 0.6 V. The device can withstand indefinite operation with inputs in the range of -0.5 V to +7.0 V. Device operation will not be adversely affected, however, input current levels will be well in excess of 100 mA.

4. Actual test conditions may vary from those designated but operation is guaranteed as specified.

5. Supply current for a given application can be accurately approximated by:

$$\frac{NCV^2F}{4}$$

where

- N = total number of device outputs
- C = capacitive load per output
- V = supply voltage
- F = clock frequency

6. Tested with all outputs changing every cycle and no load, at a 5 MHz clock rate.

7. Tested with all inputs within 0.1 V of VCC or Ground, no load.

8. These parameters are guaranteed

but not 100% tested.

9. AC specifications are tested with input transition times less than 3 ns, output reference levels of 1.5 V (except tDIS test), and input levels of nominally 0 to 3.0 V. Output loading may be a resistive divider which provides for specified IOH and IOL at an output voltage of VOH min and VOL max respectively. Alternatively, a diode bridge with upper and lower current sources of IOH and IOL respectively, and a balancing voltage of 1.5 V may be used. Parasitic capacitance is 30 pF minimum, and may be distributed.

This device has high-speed outputs capable of large instantaneous current pulses and fast turn-on/turn-off times. As a result, care must be exercised in the testing of this device. The following measures are recommended:

a. A 0.1 μF ceramic capacitor should be installed between VCC and Ground leads as close to the Device Under Test (DUT) as possible. Similar capacitors should be installed between device VCC and the tester common, and device ground and tester common.

b. Ground and VCC supply planes must be brought directly to the DUT socket or contactor fingers.

c. Input voltages should be adjusted to compensate for inductive ground and VCC noise to maintain required DUT input levels relative to the DUT ground pin.

10. Each parameter is shown as a minimum or maximum value. Input requirements are specified from the point of view of the external system driving the chip. Setup time, for example, is specified as a minimum since the external system must supply at least that much time to meet the worst-case requirements of all parts. Responses from the internal circuitry are specified from the point of view of the device. Output delay, for example,

is specified as a maximum since worst-case operation of any device always provides data within that time.

11. For the tENA test, the transition is measured to the 1.5 V crossing point with datasheet loads. For the tDIS test, the transition is measured to the ±200mV level from the measured steady-state output voltage with ±10mA loads. The balancing voltage, VTH, is set at 3.5 V for Z-to-0 and 0-to-Z tests, and set at 0 V for Z-to-1 and 1-to-Z tests.

12. These parameters are only tested at the high temperature extreme, which is the worst case for leakage current.

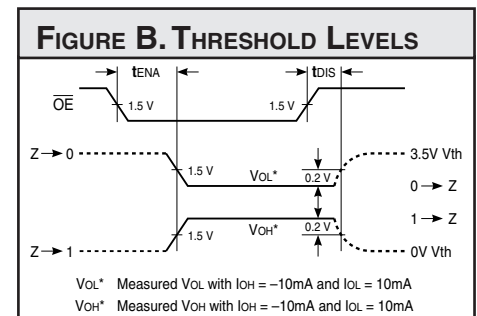
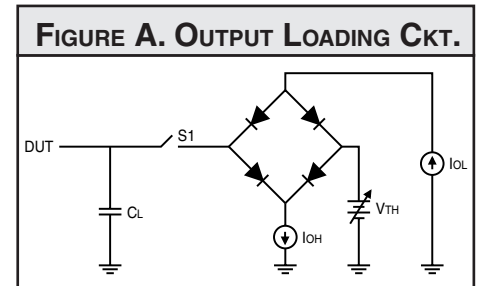

16 x 16-bit Multiplier-Accumulator

LMA1010 — ORDERING INFORMATION

64-pin

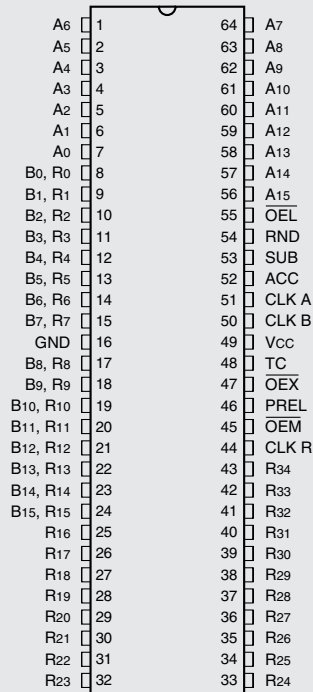

Discontinued Package

68-pin

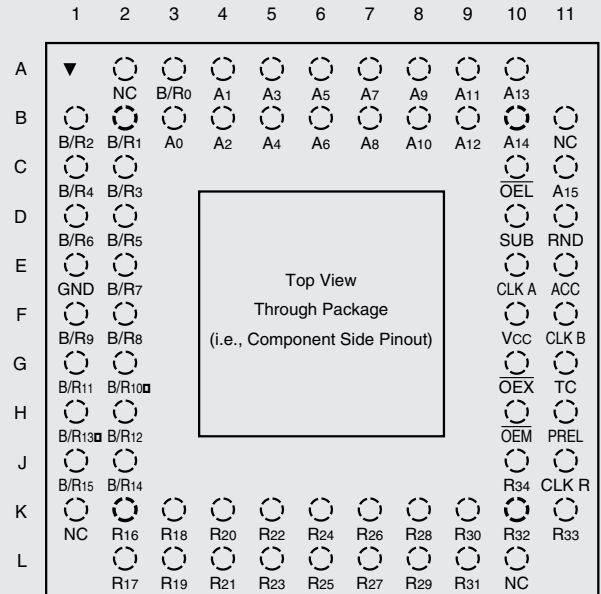

Discontinued Package

Speed	Sidebrazed Hermetic DIP (D6)	Ceramic Pin Grid Array (G2)
	0°C to +70°C — COMMERCIAL SCREENING	
	-55°C to +125°C — COMMERCIAL SCREENING	
	-55°C to +125°C — MIL-STD-883 COMPLIANT	

LMA2010 — ORDERING INFORMATION

68-pin

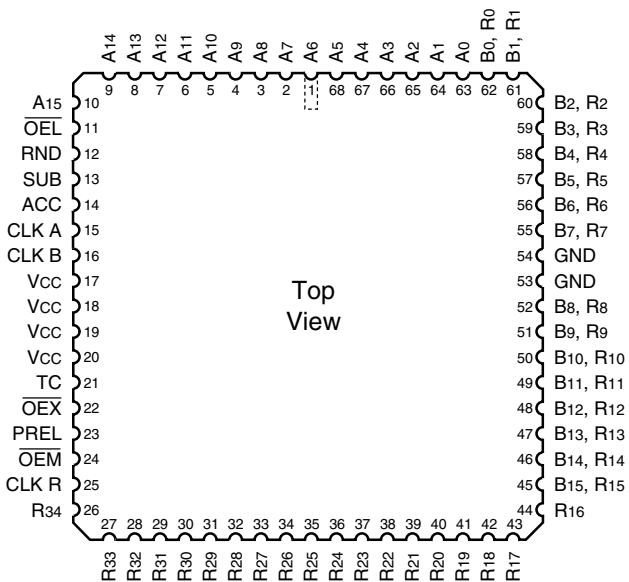

Speed	Plastic J-Lead Chip Carrier (J2)			
0°C to +70°C — COMMERCIAL SCREENING				
35 ns 25 ns	LMA2010JC35 LMA2010JC25			
-40°C to +85°C — INDUSTRIAL SCREENING				
25 ns	LMA2010JI25			
-55°C to +125°C — MIL-STD-883 COMPLIANT				